

E1369

---



Zero-Channel RAID Board  
(AZCRB)

**Installation Guide**

First Edition V1  
August 2003

---

No part of this documentation, including the products and software described in it, may be reproduced, transmitted, transcribed, stored in a retrieval system, or translated into any language in any form or by any means, except documentation kept by the purchaser for backup purposes, without the express written permission of ASUSTeK COMPUTER INC. ("ASUS").

ASUS PROVIDES THIS DOCUMENTATION "AS IS" WITHOUT WARRANTY OF ANY KIND, EITHER EXPRESS OR IMPLIED, INCLUDING BUT NOT LIMITED TO THE IMPLIED WARRANTIES OR CONDITIONS OF MERCHANTABILITY OR FITNESS FOR A PARTICULAR PURPOSE. IN NO EVENT SHALL ASUS, ITS DIRECTORS, OFFICERS, EMPLOYEES OR AGENTS BE LIABLE FOR ANY INDIRECT, SPECIAL, INCIDENTAL, OR CONSEQUENTIAL DAMAGES (INCLUDING DAMAGES FOR LOSS OF PROFITS, LOSS OF BUSINESS, LOSS OF USE OR DATA, INTERRUPTION OF BUSINESS AND THE LIKE), EVEN IF ASUS HAS BEEN ADVISED OF THE POSSIBILITY OF SUCH DAMAGES ARISING FROM ANY DEFECT OR ERROR IN THIS DOCUMENTATION OR PRODUCT.

Product warranty or service will not be extended if: (1) the product is repaired, modified or altered, unless such repair, modification or alteration is authorized in writing by ASUS; or (2) the serial number of the product is defaced or missing.

Products and corporate names appearing in this documentation may or may not be registered trademarks or copyrights of their respective companies, and are used only for identification or explanation and to the owners' benefit, without intent to infringe.

For documentation updates, visit the ASUS website at [www.asus.com.tw](http://www.asus.com.tw).

The specifications and information contained in this documentation are furnished for informational use only, and are subject to change at any time without notice, and should not be construed as a commitment by ASUS. ASUS assumes no responsibility or liability for any errors or inaccuracies that may appear in this documentation, including the products and the software described in it.

Copyright © 2003 ASUSTeK COMPUTER INC. All Rights Reserved.

## Contents

Conventions .....	4
Symbols .....	4
Typography .....	4
Welcome! .....	5
1. Package contents .....	5
2. Features .....	6
3. Board layout .....	8
4. Board installation .....	9
5. RAID configuration .....	13
5.1 Configuring arrays and logical drives .....	15
5.2 Easy Configuration .....	16
5.3 New Configuration .....	25
5.3 View/Add Configuration .....	28
ASUS Contact Information .....	32

---

## Conventions

### Symbols



**NOTE** Tips and additional information.



**CAUTION** Information to prevent damage to the components.

### Typography

<Enter> Indicates a keyboard key to press

<Ctrl><M> Indicates a key combination to press simultaneously or consecutively

*text input* Indicates text or command that you have to type on the screen

## Welcome!

Thank you for buying the ASUS Zero-Channel RAID board (AZCRB)! Now, you can create and manage multiple disk arrays within your ASUS AP1600R 1U system with PR-DSLR533 motherboard. With the convenient online management and configuration utilities bundled, creating a RAID system has never been easier.

### 1. Package contents

Check the following items in your ASUS Zero-Channel RAID board package. Contact your retailer if any item is damaged or missing.

- ASUS Zero-Channel RAID Board
- Screws and standoffs
- Support CD
- Installation guide



If any of the items is damaged or missing, contact your dealer immediately.

## 2. Features

The AZCRB is a proprietary daughterboard for the RAID connectors on the ASUS **PR-DLSR533** motherboard. The AZCRB includes the Intel® GC80303 integrated I/O processor and 64MB ECC SDRAM cache, and 64MB ECC SDRAM.

### RAID features

- RAID levels 0/1/5 support
- Background initialization for Quick RAID 5 setup
- 40 logical drives per controller
- Auto-resume during array rebuild or reconstruction if the system shuts down
- Variable stripe size for all logical drives
- Supports multiple caching policies
  - Write-back/Write-through
  - Read Ahead: disable/enable/adaptive
  - Cached direct I/O

---

### **Fault tolerance**

- COD (Configuration on Disk) and NVRAM
- Auto-detection of failed drives
- Automatic and transparent rebuild of hot spare drives
- Hot-swapping of drives without shutting the system down
- SAF-TE enclosure management support
- SMART support

### **Utilities**

- Power Console Plus for Windows® NT®/2000/XP/203
- MegaManager
- WebBIOS™

### 3. Board layout

The two connectors underneath the board fit the RAID connectors on the PR-DLSR533 motherboard.

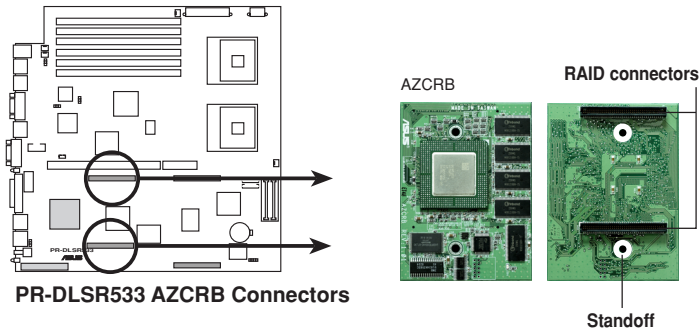

Make sure that your system motherboard is PR-DLSR533. Only the proprietary RAID connectors on this motherboard will support the AZCRB.



## 4. Board installation



Before handling the board, touch a bare metal portion of the system to discharge static electricity from your body. Wear a wrist strap grounded to the system chassis when handling the board.

### To install the board:

1. Make sure that the system is off.
2. Remove the system cover to access the RAID connectors on the motherboard. Refer to the AP1600R system manual for instructions.
3. Remove the PCI riser card and bracket assembly by pulling up the metal lever to release and detach the assembly from the chassis.

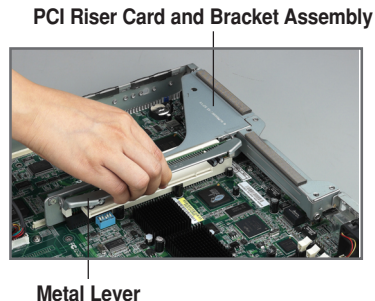

4. Locate the proprietary RAID connectors on the motherboard.
5. Remove the board from its anti-static packaging.

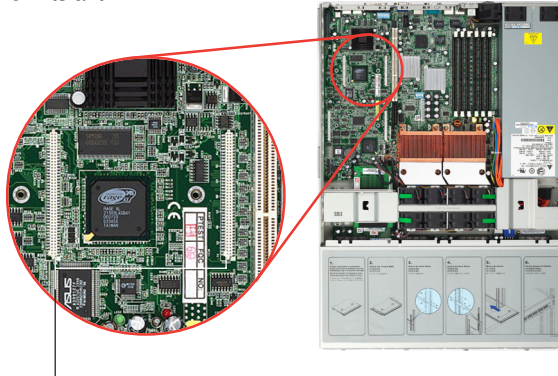

RAID connectors on the motherboard

- 
- Position the board as shown, then plug the RAID connectors to the corresponding connectors on the motherboard.  
The two holes (with standoffs) on the board should also align with the holes beside the RAID connectors on the motherboard.

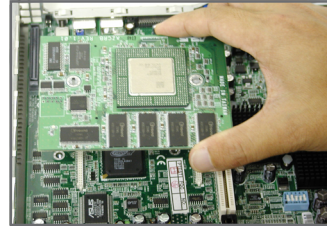

- Use a Phillips screwdriver to secure the board with two screws through the holes.

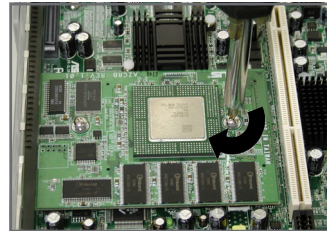

8. When the board is secure, replace the riser card assembly into the chassis.
9. Replace the chassis cover.

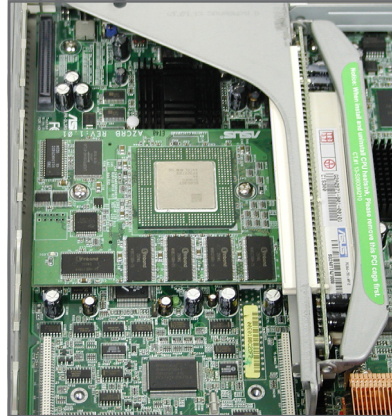

---

Install the hard disks following the instructions on your system manual.

---

## 5. RAID configuration

The MegaRAID BIOS on your AZCRB board includes the MegaRAID Configuration Utility. Use this utility to create and configure disk arrays and logical drives.

The MegaRAID Configuration Utility is independent of the operating system so you have to start the utility during the Power-On Self-Tests (POST), prior to entering the operating system.

### **To start the MegaRAID Configuration Utility:**

Turn on the system. During POST, hold the <Ctrl> and press <M> when the following message appears:

**Press <Ctrl><M> to run MegaRAID BIOS Configuration Utility**

The MegaRAID BIOS Configuration Utility menu appears. See the menu image on the next page.



---

If you do not press <Ctrl><M> within a few seconds after the message, the system continues with the normal boot procedure.

---

The initial menu of the MegaRAID BIOS Configuration Utility shows the Management menu. Each option in the menu leads to different sub-menus that allow you to create and configure RAID drives.

### Management menu options

#### Configure

Select to configure physical arrays and logical drives.

#### Initialize

Select to initialize one or more logical drives.

#### Objects

Select to access controllers, logical drives, and physical drives individually.

#### Format

Select to format hard disk drives.

#### Rebuild

Select to rebuild failed hard disk drives.

#### Check Consistency

Select to verify the correctness of the redundancy data in logical drives configured as RAID level 0, 1, or 5.

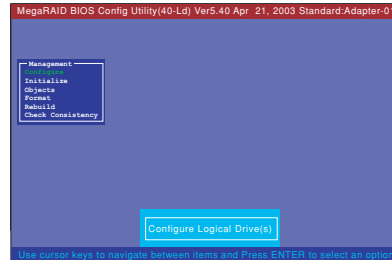

## 5.1 Configuring arrays and logical drives

Depending on your current drive configuration or number of existing drives, you may create physical arrays and logical drives using either one of the following methods:

- Easy Configuration
- New Configuration
- View/Add Configuration

### General procedure for configuring arrays and logical drives

1. Select a configuration method.
2. Designate hot spares (optional).
3. Create arrays using the available physical drives.
4. Define logical drive(s) using the space in the arrays.
5. Save the configuration information.
6. Initialize the new logical drives.



---

The procedure for each configuration method varies on the level of user input. The succeeding sections give specific instructions on the method that you wish to use. Refer to the **MegaRAID Configuration Software Guide** in the support CD for detailed information.

---

## 5.2 Easy Configuration

The Easy Configuration method allows you to create a basic logical drive configuration where every physical array you define is automatically associated with one logical drive.

If you have an existing logical drive configuration, using this method does not erase the current configuration information.

This method allows you to change the **RAID level**, **stripe size**, **write policy**, **read policy**, and **cache policy** parameters.

### To use Easy Configuration:

1. From the Management menu, use the arrow keys to highlight **Configure**, then press <Enter>.
2. Select **Easy Configuration**, then press <Enter>.

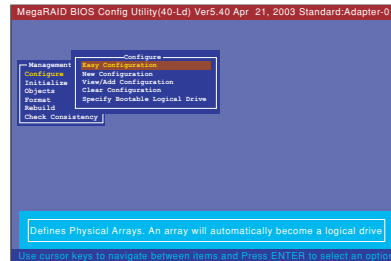



The Easy Configuration-ARRAY SELECTION MENU appears. Use the **command bar hot keys** to perform the configuration functions.

Press:

- <F2> to display the manufacturer data and error count for the selected drive
- <F3> to display the logical drives that have been configured
- <F4> to designate the selected drive as a hot spare

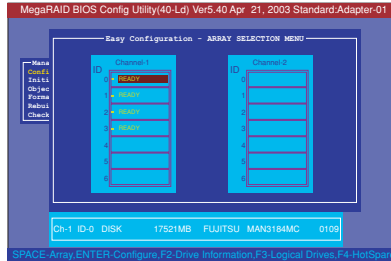

Command bar hot keys



The command bar hot keys change depending on the active configuration window.

- Use the arrow keys to select a specific physical drive, then press the <Space bar> to associate the selected drive with the current array. The indicator for the selected drive changes from **READY** to **ONLIN Axx-xx**.

>> where **Axx-xx** means:

A[array number]-[drive number]

For example, **ONLIN A01-01** means disk drive 1 in array 1.

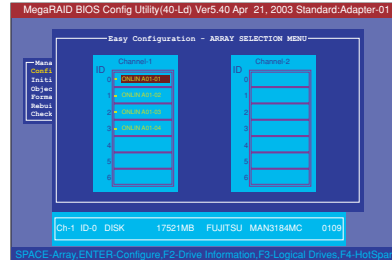

If possible, use identical drives (with the same type and capacity) in one array. If you use drives of different capacities in one array, all the drives are treated as if they have the capacity of the **smallest** drive in the array.

---

The number of physical drives in an array determines the RAID levels that can be implemented with the array.

**RAID 0** requires one or more physical drives

**RAID 1** requires exactly two physical drives

**RAID 3** requires at least three physical drives

**RAID 5** requires at least three physical drives



---

The ASUS AP1600R system with PR-DLSR533 motherboard supports four (4) hard disk drives (HDDs) that may be configured to RAID 0 or RAID 5 using the AZCRB. If you wish to configure more HDDs into multiple physical arrays (spanning of arrays), you may opt to connect a storage system to the AP1600R. Refer to the **MegaRAID Configuration Software Guide** in the support CD for detailed information on this feature.

---

- When finished creating the array, press <Enter> to start the configuration. The **Logical Drive Configured** screen appears showing the logical drive being configured and the existing logical drives, if any.

```
Logical Drive Configured
LD RAID Size #Stripes StrpSz Drive-State
1 5 52563MB 4 64KB OPTIMAL
```

- Set the RAID level for the logical drive. Highlight **RAID** then press <Enter> to display the available RAID levels.
- Select your desired RAID level, e.g. **RAID 5**, and press <Enter> to confirm.

```
Logical Drive 1
RAID = 5
Size = 52563MB
Advanced Menu
Accept
```

```
RAID Level
RAID = 0
RAID = 5
```

7. Select the **Advanced Menu** to set the stripe size, write policy, read policy, and cache policy.

```
Logical Drive 1
RAID = 5
Size = 52563MB
Advanced Menu
Accept

Advanced
StripeSize = 64MB
Write Policy = WRTHRU
Read Policy = NORMAL
Cache Policy = Direct I/O

Cache Policy
Cache IO
Direct IO
```

**Stripe Size** - specifies the size of the segments written to each disk in an array. You can set the stripe size to either 2KB, 4KB, 8KB, 16KB, 32KB, 64KB, or 128KB. A larger stripe size allows better performance when your system does sequential reads often. Other set to a smaller stripe size.

**Write Policy** - sets the caching method. In **Write-back** method, the controller sends a data transfer completion signal to the host when the controller cache has received all the data in a transaction. In **Write-through**, the controller sends a data transfer completion signal to the host when the disk subsystem has received all the data in a transaction. Write-through allows more data security than Write-back, but the latter allows better performance.

---

**Read Policy** - enables the SCSI read-ahead feature for the logical drive. The configuration options are Normal, Read-ahead, or Adaptive. In **Normal** setting, the controller does not use read-ahead for the current logical drive. In **Read-ahead**, the controller uses read-ahead for the current logical drive. In **Adaptive** setting, the controller begins using read-ahead if the two most recent disk accesses occurred in sequential sectors. If all the requests are random, the algorithm reverts to Normal, but succeeding requests are still evaluated for possible sequential operation.

**Cache Policy** - applies to reads on a specific logical drive, and does not affect the read-ahead cache. **Cache I/O** specifies that all reads are buffered in the cache memory. **Direct I/O** specifies that reads are not buffered in the cache memory. Data is transferred concurrently to cache and host. Direct I/O does not override the cache policy settings.

8. When finished defining the current logical drive, select **Accept** then press <Enter>.
9. If you have remaining unconfigured disk drives, the array selection menu re-appears. Configure the drives following steps 3 to 8.
10. When done, press <Esc> to exit Easy Configuration. A screen appears with a list of the configured logical drive(s).

```
Logical Drive 1
RAID = 5
Size = 52563MB
Advanced Menu
Accept
```

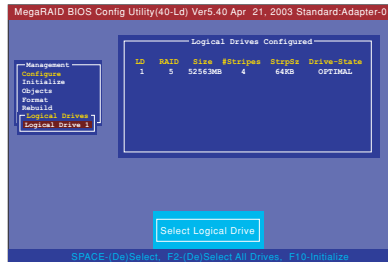



Before doing the next steps, make sure that you do not have data in the hard disk drives that you wish to keep. Initializing erases all data stored in the drives!

11. From the Management menu, use the arrow keys to highlight **Initialize**, then press <Enter>.
12. When prompted, select **YES** to start initializing the logical drive(s) that you have configured.

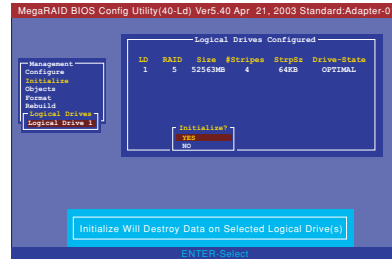



## 5.3 New Configuration

The New Configuration method allows you to discard the existing configuration information, and configure a new array and logical drives. This method lets you change the **RAID level**, **stripe size**, **write policy**, **read policy**, and **cache policy** parameters, and associate logical drives with multiple or partial arrays.



Choosing New Configuration **erases** the existing configuration information on the selected controller. If you want to keep the current configuration and add other drives to the array, select View/Add Configuration. See page 28.

### To use New Configuration:

1. From the Management menu, use the arrow keys to highlight **Configure**, then press <Enter>.
2. Select **New Configuration**. The New Configuration-ARRAY SELECTION MENU appears showing the devices currently connected to the controller.

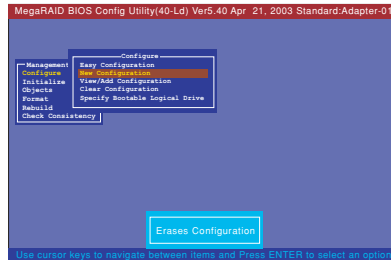

The New Configuration-ARRAY SELECTION MENU appears. Use the **command bar hot keys** to perform the configuration functions.

Press:

- <F2> to display the manufacturer data and error count for the selected drive
- <F3> to display the logical drives that have been configured
- <F4> to designate the selected drive as a hot spare
- <F10> to display the logical drive configuration screen



The command bar hot keys change depending on the active configuration window.

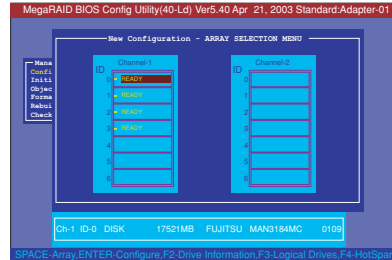

- Use the arrow keys to select a specific physical drive, then press the <Space bar> to associate the selected drive with the current array. The indicator for the selected drive changes from **READY** to **ONLIN Axx-xx**.

>> where **Axx-xx** means:

A[array number]-[drive number]

For example, **ONLIN A01-01** means disk drive 1 in array 1.



If possible, use identical drives (with the same type and capacity) in one array. If you use drives of different capacities in one array, all the drives are treated as if they have the capacity of the **smallest** drive in the array.

- Follow steps 4 to 12 in section “5.2 Easy Configuration.” For instructions on creating multiple arrays, refer to the **MegaRAID Configuration Software Guide** in the support CD.



## 5.3 View/Add Configuration

The View/Add Configuration lets you examine the existing configuration and/or specify additional arrays and logical drives.

### To use View/Add Configuration:

1. From the Management menu, use the arrow keys to highlight **Configure**, then press <Enter>.

2. Select **View/Add Configuration**.

The View/Add Configuration-ARRAY SELECTION MENU appears showing the devices currently connected to the controller.

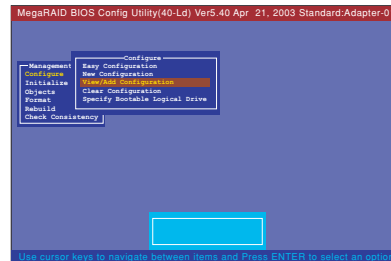

3. Follow steps 3 to 12 in section “5.2 Easy Configuration.” For instructions on creating multiple arrays, refer to the **MegaRAID Configuration Software Guide** in the support CD.



***NOTES***

---

---

---

---

---

---

---

---

---

---

---

---



**NOTES**

---

---

---

---

---

---

---

---

---

---

---



***NOTES***

---

---

---

---

---

---

---

---

---

---

---

---

## ASUS Contact Information

### **ASUSTeK COMPUTER INC. (Asia-Pacific)**

#### **Marketing**

Address: 150 Li-Te Road  
Peitou, Taipei, Taiwan 112  
General Tel.: +886-2-2894-3447  
General Fax: +886-2-2894-3449  
Web Site: [www.asus.com.tw](http://www.asus.com.tw)

#### **Technical Support**

MB/Others (Tel): +886-2-2890-7121 (English)  
Notebook (Tel): +886-2-2890-7122 (English)  
Desktop/Server (Tel): +886-2-2890-7123 (English)  
Support Fax: +886-2-2890-7698

### **ASUS COMPUTER INTERNATIONAL (America)**

#### **Marketing**

Address: 44370 Nobel Drive, Fremont,  
CA 94538, USA  
General Fax: +1-502-933-8713  
General Email: [tmd1@asus.com](mailto:tmd1@asus.com)

#### **Technical Support**

Support Fax: +1-502-933-8713  
General Support: +1-502-995-0883  
Web Site: [usa.asus.com](http://usa.asus.com)  
Support E-mail: [tsd@asus.com](mailto:tsd@asus.com)

### **ASUS COMPUTER GmbH (Germany and Austria)**

#### **Marketing**

Address: Harkortstr. 25 D-40880 Ratingen,  
BRD, Germany  
General Fax: +49-2102-9599-31  
General Email: [sales@asuscom.de](mailto:sales@asuscom.de)  
(for marketing requests only)

#### **Technical Support**

Support Hotline: +49-2102-95990 (Components)  
+49-2102-959910 (Notebook PC)  
+49-2102-959911  
Support Fax: +49-2102-959911  
Support (Email): [www.asuscom.de/support](http://www.asuscom.de/support)  
(for online support)  
Web Site: [www.asuscom.de](http://www.asuscom.de)

15-061095000

ASUS Zero-Channel RAID Board